

User's Guide

Model ProRACK 7220 Series
Rack Mount System

- 2 redundant, hot swappable 300 watt power supplies
- 10-fan cooling system: 4 fans for passive backplane and single board computer(s), 4 fans for disk drives and 1 fan for each power supply
- Designed for a CSS 20-slot passive backplane with single board computer(s)
- 19" wide x 10.5" wide x 26" deep

coming from computing equipment.

Note: This equipment has been tested and found to comply with the limits for a Class A digital device pursuant to Part 15 of the FCC Rules. These limits are designed to provide reasonable protection against harmful interference in a residential installation. This equipment generates, uses, and can radiate radio frequency energy and, if not installed and used in accordance with the instructions, may cause harmful interference to radio communications. However, there is no guarantee that interference will not occur in a particular installation. If this equipment does cause harmful interference to radio or television reception, which can be determined by turning the equipment off and on, the user is encouraged to try to correct the interference by one or more of the following measures:

- Reorient or relocate the receiving antenna.
- Increase the separation between the equipment and receiver.
- Connect the equipment into an outlet on a circuit different from that to which the receiver is connected.
- Consult the dealer or an experienced radio/TV technician for help.

CSS Labs is not responsible for any radio or television interference caused by unauthorized modifications to this equipment. Operation with non-certified peripherals is likely

device is in violation of U.S. Federal law and will not allow the device to meet the maximum emission limits.

CAUTION: Any changes or modifications not expressly approved by the grantee of this device could void the user's authority to operate the equipment.

CSS Laboratories Incorporated shall not be liable for technical or editorial errors or omissions contained herein; nor for incidental or consequential damages resulting from the furnishing, performance, or use of this material.

No part of this publication may be reproduced, stored in a retrieval system, or transmitted, in any form or by any means, mechanical, photocopying, recording or otherwise, without the prior written permission of CSS Laboratories, Inc.

Product names mentioned herein are for identification purposes only, and may be trademarks and/or registered trademarks of their respective companies.

Section 1 - Introduction

Overview	1-1
The System Case	1-1
The Front Panel	1-2
The Rear Panel	1-3
The Keyboard (optional)	1-3
Power Supply	1-3

Section 2 - Setting Up the System

Overview	2-1
Unpacking the System	2-1
Assembling the System	2-2
The Monitor (optional)	2-2
The Keyboard (optional)	2-3
The Power Cord	2-3
The Mouse (optional)	2-3
The Printer (optional)	2-4
Mounting the ProRACK In Your Rack	2-4
Turning the System On	2-6
Before Powering Up	2-6
Starting Up	2-6

The Front Panel	3-1
Segment Power LED/Power Switch	3-2
Segment Reset Button	3-2
Main Power ON/OFF Switch	3-2
Floppy Drive LED	3-2
Floppy Diskettes	3-3
Installing Disk Drives	3-4
Using The Power Supplies	3-5
Setting 110 or 220 VAC	3-5
Swapping Power Supplies	3-5
Changing The Fuse	3-6
Rebooting The System	3-7
Standard Maintenance	3-8

Overview

The ProRACK 7220 Rack Mount System is a hardened industrial grade computer that provides many versatile features. The industrial chassis offers expansion capabilities for large, modular system configurations.

The system supports up to five external 5.25 inch front loading drives and two external 3.5 inch disk drives, secured by a locking front panel.

The System Case

The system case measures 19 inches wide x 10.5 inches high x 26 inches deep.

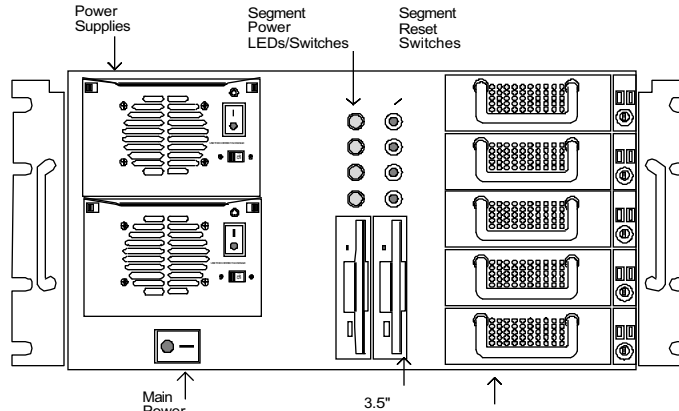

- System Power
- Disk
- Turbo
- Keylock.

The LEDs are visible through a window in the locking front door.

The **Segment Power LED's** lets you know that the segment is receiving power from the power supply.

The **Disk LED** lights whenever the hard disk is accessed by the system.

The **Turbo LED** lights while the system is running in the faster mode.

The **Keylock LED** lights when the keylock is engaged, prohibiting use of the system's keyboard.

The front panel provides a power ON/OFF switch and reset button for each segment of any CSS multi-segment passive backplane board.

The system's dual redundant power supplies are accessed through the front of the chassis. Each supply has its own 110/220 volt switch ON/OFF switches and handles. The unit's housing provides a main power switch and fuse.

- Serial port options
- Parallel port options
- Keyboard connector
- Expansion slot covers

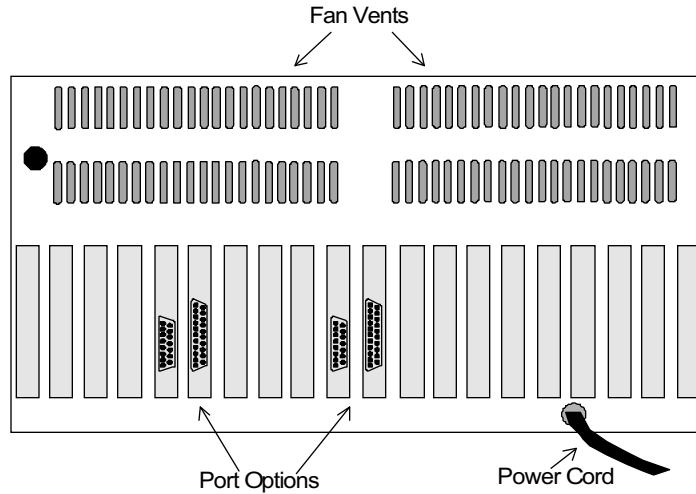

Figure 1-2: The Rear Panel

The Keyboard (optional)

The Rack Mount System comes with an optional keyboard.

60 Hz, or 220 VAC at 50 Hz. The system is also available with an optional 48 VDC 250 watt power supply and optional 400 watt AC supply.

Overview

This section describes the assembly of the ProRACK System. Once everything is connected, the system will be ready to power up and put to use.

You will mount the slide rails on the system chassis and install the ProRACK in your 19" rack or closet.

You will also connect the monitor cable and the keyboard cable to the system via connectors on the rear panel of the case. You will also connect the power cord to the wall outlet.

Unpacking the System

Before proceeding, review this list:

- The system unit
- Keyboard (optional)
- Monitor (optional)
- Mouse (optional)

(figure 2-1).

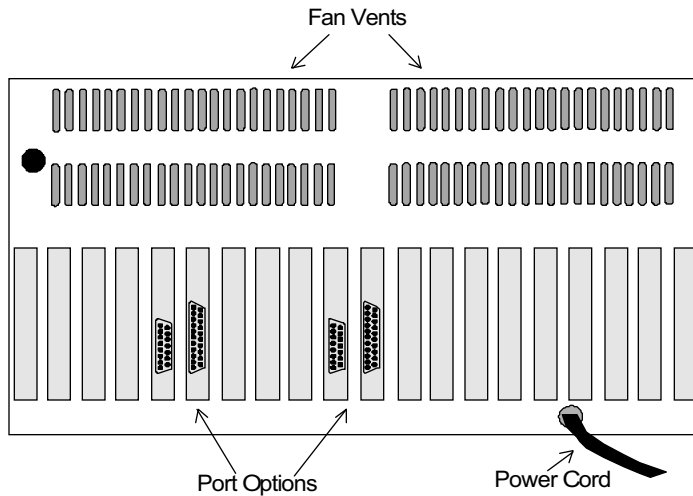

Figure 2-1: The Rear Panel

The Monitor (optional)

Two cables are attached to the rear of the monitor. The grounded, three-pronged cable plugs into a grounded power source. The other cable carries data to the monitor, and plugs into the system's video adapter card.

- 1) Locate the video adapter's connector on the rear panel. The adapter is installed in one of the expansion slots.
- 2) Press the plug into the video connector.

- 2) Position the keyboard cable plug so that the pins match the connector on the case.
- 3) Firmly press the keyboard's plug into the system keyboard connector.

The Power Cord

The ProRACK Rack Mount System comes with an insulated, grounded, three-pronged power cord.

Plug the male end of the power cord into a grounded outlet.

The Mouse (optional)

The ProRACK Rack Mount system can be configured with an optional mouse. For software installation, refer to documentation provided with the mouse.

- 1) Locate the nine-pin serial port connector on the rear of the single board computer. The connector has one row of five pins and one row of four pins.
- 2) Position the mouse plug next to the serial port on the rear of the case and press the plug firmly into place.

- 2) Press the printer's data plug firmly into the parallel port connector on the rear panel.

Plug the power connectors for all the devices into a grounded, three-pin power supply. **CSS recommends that you use a power surge protector with the system and peripheral equipment.**

Mounting the ProRACK In Your Rack

Follow these steps to install the slide rails on the ProRACK chassis and mount the ProRACK in your rack or closet:

- 1) Slide the smallest interior portion of the slide completely out of the assembly.
- 2) Mount the smallest interior portion of the slide to the chassis, using the #6/32 screws provided.
- 3) Mount the forward bracket (smallest of the pair) to the front of the largest portion of the slide. Use two of the #10 flat head screws provided.
 - The flat head of the screw will be on the inside of the slide.
 - Put a flat head screw washer next to the bracket

- 4) Mount the rear bracket (longest of pair) to the rear of the largest portion of the slide.
 - This bracket is an extender. You will need to match up holes that will let you mount the bracket to the rear rail.
 - Hand tighten the screws and nuts. You will tighten these after the ProRACK is installed.
- 5) Reassemble the slides.
- 6) When you mount the ProRACK, the front of the bracket will mount to the rear of your rack's forward rail. The rear extender may be mounted in front of, or behind the rear rail. The brackets are mounted to the RETMA rails using #10 screws.

If the operating system was not pre-installed, refer to the **User's Guide** provided for that software. The documentation provides instructions to “boot” the first time.

Starting Up

Follow these steps:

- 1) Power up all peripherals first, i.e. printer and monitor.
- 2) Turn the system's ON/OFF toggle to the ON position.
- 3) The system will boot, and load its operating system.

The system's BIOS is configured at the factory with default settings. You can reconfigure the BIOS at any time. Refer to your system's **Configuration Utilities** documentation.

Overview

This section describes your system's features:

- The Front Panel LEDs and Controls
- Floppy Diskettes
- Installing Disk Drives
- Using The Power Supplies
- Changing The Fuse
- Rebooting The System
- Maintaining The System

In the event that one or more of the fans installed in the ProRACK fails, contact your nearest CSS Support personnel.

The Front Panel

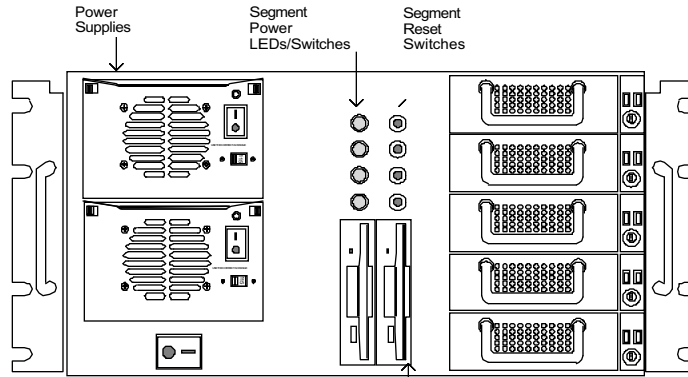

Segment Reset Button

Each segment has its own reset button.

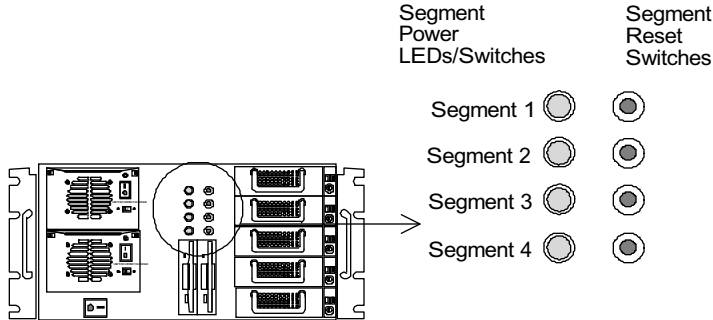

Figure 3-2: The Segment LEDs and Buttons

Main ON/OFF Switch

Located directly beneath the dual power supplies, the Main ON/OFF Switch controls both supplies. Placing the switch in the OFF position shuts down power to the entire system.

Floppy Drive LED

The floppy drive LED lights when the drive is accessing the 3.5" diskette. Do not attempt to remove the diskette from the

inches per side.

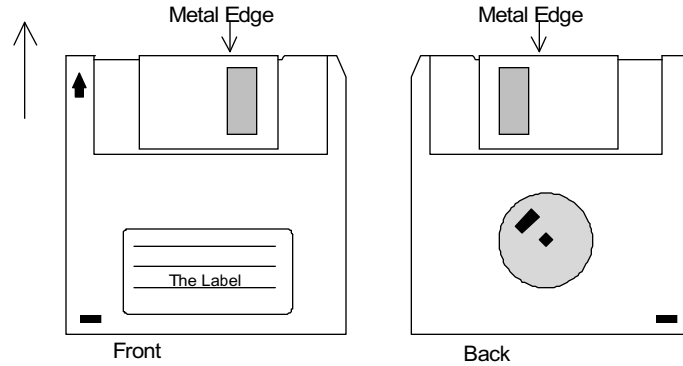

Figure 3-3: 3.5 Inch Diskette

The diskette is inserted metal-edge first, with the label side facing up.

steps to install disk drives:

- 1) Remove the chassis' cover.
- 2) Mount the drive in the cage. Use the screws provided with the disk drive. Be careful not to over tighten the screws.
- 3) Connect one of the disk drive power plug to the drive. The plug and socket are notched.
- 4) Connect the cables required for the drive, and controller. Refer to documentation provided by the drive and controller manufacturers.
- 5) Connect the cable for the drive's activity LED to the front panel display, if applicable.
- 6) Replace the chassis' cover.
- 7) Reconfigure the system utilities and format the new drive, as needed.

Each unit comes with a number of power connections, external ON/OFF switch, automatic short circuit shutdown and can be configured to operate with 110 VAC or 220 VAC.

Setting 110 or 220 VAC

The power supply may be configured to operate with either 110 VAC or 220 VAC. Simply locate the red selector switch on the back of the system case.

The switch is clearly marked and displays the setting you have selected.

Swapping Power Supplies

Be sure to put the ON/OFF switch in “OFF” position on the power supply before you remove it from the system.

The new supplies’ ON/OFF switch should also be in the “OFF” position while you install it. To swap supplies,

- 1) Put the ON/OFF switch in the “OFF” position.
- 2) Slide the release tabs toward the center of the unit.
- 3) While holding the tabs, grasp the supplies’ handle and

switch is set to the correct voltage.

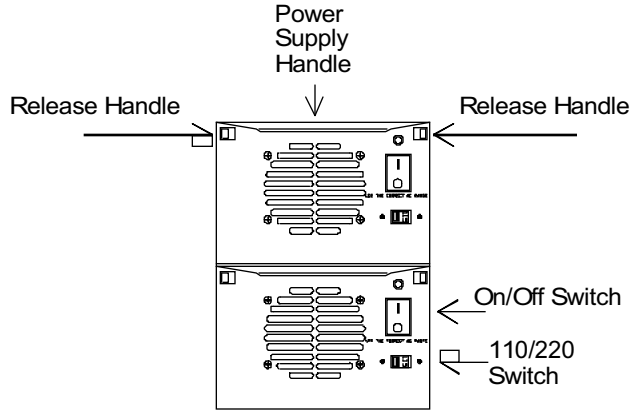

Figure 3-4: Swapping the Power Pupplies

Changing The Fuse

The power supplies' fuse regulates small electrical fluctuations in the current provided from the main power source. Spiking power may cause the fuse to burn out. If this happens, the supplies are inoperable and the fuse must be replaced.

To replace it, simply unscrew the fuse and pull it from the power supply housing. Insert a fresh fuse, rotating it until it locks into place.

- 1) Cold or Hard Boot - Power to the system is turned off and then turned back on. The system starts up, runs the memory test and boots from the system disk. A cold boot is more thorough than a warm boot.
- 2) Warm or Soft Boot - Use the keyboard command: <Ctrl> <Alt> . A warm boot takes less time than a cold boot. Instead of restarting from power-down, the system simply clears RAM and runs certain commands from the boot files.

- Do not eat, drink or smoke near the computer.
- Use a surge protector with your system and any peripheral devices. Surges of power can destroy computer components and can also destroy data on an entire hard drive.
- Do not allow any magnetic sources to come near the machine, such as magnets or electric motors. These will damage data on your disks.
- Do not let the computer share an electrical circuit with a noisy electric motor, such as a blender or a vacuum cleaner.
- Ground yourself before touching any exposed circuitry by touching the system case. This discharges static electricity in your body, which can damage delicate components.

Should one or more of the fans installed in the ProRACK fail, please contact your nearest CSS Support personnel.