

User's Guide

ProRACK 4500 Series Rack Mount System



1641 McGaw Avenue
Irvine, California 92614

CSS ProRACK 4500 Features

- 3 external and 2 internal 3.5 inch drive bays or 3 half-height 5.25 inch drive bays
- 200 watt power supply, 90 VAC to 240 VAC, 50 Hz to 60 Hz (optional dual hot swappable 250 watt power supplies)
- 112 CFM fan
- Can be configured with 12-slot or 8-slot motherboards or passive backplanes with single board computers (SBC)
- 16 gauge steel chassis; 19" W x 7" H x 20" D

FCC Standards

The FCC (Federal Communications Commission) restricts the amount of radiation and radio frequency emissions coming from computing equipment.

Note: This equipment has been tested and found to comply with the limits for a Class A digital device pursuant to Part 15 of the FCC Rules. These limits are designed to provide reasonable protection against harmful interference in a residential installation. This equipment generates, uses, and can radiate radio frequency energy and, if not installed and used in accordance with the instructions, may cause harmful interference to radio communications. However, there is no guarantee that interference will not occur in a particular installation. If this equipment does cause harmful interference to radio or television reception, which can be determined by turning the equipment off and on, the user is encouraged to try to correct the interference by one or more of the following measures:

- Reorient or relocate the receiving antenna.
- Increase the separation between the equipment and receiver.
- Connect the equipment into an outlet on a circuit different from that to which the receiver is connected.
- Consult the dealer or an experienced radio/TV technician for help.

CSS Labs is not responsible for any radio or television interference caused by unauthorized modifications to this equipment. Operation with non-certified peripherals is likely to result in interference to radio and TV reception.

To ensure compliance to FCC non-interference regulations, peripherals attached to this device require shielded I/O cables.

NOTICE: The use of a non-shielded I/O cable with this device is in violation of U.S. Federal law and will not allow the device to meet the maximum emission limits.

CAUTION: Any changes or modifications not expressly approved by the grantee of this device could void the user's authority to operate the equipment.

NOTICE

The information within this manual is subject to change without notice.

CSS Laboratories Incorporated shall not be liable for technical or editorial errors or omissions contained herein; nor for incidental or consequential damages resulting from the furnishing, performance, or use of this material.

No part of this publication may be reproduced, stored in a retrieval system, or transmitted, in any form or by any means, mechanical, photocopying, recording or otherwise, without the prior written permission of CSS Laboratories, Inc.

Product names mentioned herein are for identification purposes only, and may be trademarks and/or registered trademarks of their respective companies.

Table of Contents

Section 1 - Introduction

Overview	1-1
The System Case	1-1
The Front Panel	1-2
5.25 Inch Drive Bay	1-2
3.5 Inch Drive Bay	1-3
The Rear Panel	1-3
The Keyboard (Optional)	1-4
The Power Supply	1-4

Section 2 - Setting Up the ProRACK

Overview	2-1
Unpacking the ProRACK	2-1
Assembling the ProRACK	2-2
The Monitor (optional)	2-2
The Keyboard (optional)	2-3
The Power Cord	2-3
The Mouse (optional)	2-4
The Printer (optional)	2-4
Turning the ProRACK On	2-4
Before Powering Up	2-4
Starting Up	2-5

Section 3 - Using the ProRACK

The Front Panel	3-1
The Front Panel	3-1
Features	3-1
Front Panel LEDs	3-2
The Keyboard (Optional)	3-3
Floppy Diskettes	3-3
Rebooting the Computer	3-4
Installing Drives	3-4
Using the Power Supply	3-5
Setting 110 VAC or 220 VAC	3-5
Standard Maintenance	3-6

Section 1 - Introduction

Overview

The ProRACK 4500 Rack Mount system is a hardened industrial grade chassis which supports up to three external and two internal 3.5 inch disk drives or three 5.25 inch half-height disk drives, and a locking front panel.

In addition to a wide variety of hard disk drives, the drive bays can be configured with 1.44 MB, 1.2 MB floppy drives, CD-ROM, optical and tape backup drives.

The assembly is powered by a 200 watt power supply. This unit is also available with dual hot swappable 250 watt power supplies.

The ProRACK 4500 is cooled by a 112 CFM fan. Additionally, the power supply (or supplies) provides its own fan.

The ProRACK Case

The chassis measures 7 inches high x 19 inches wide x 20 inches deep.

The Front Panel

The front panel provides access to the following features:

- Three external 5.25” half-height drive bays
- Main power ON/OFF switch
- Keyboard keylock
- Disk access and system power LEDs

The power LED lets you know that the system is receiving power from the power supply. The disk access LED lights whenever the hard disk is accessed by the system.

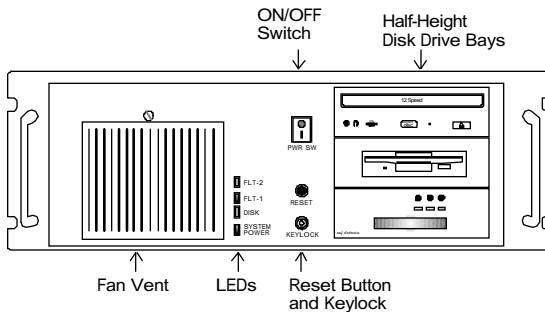

Figure 1-1: The Front Panel

FLT-1 and FLT-2 LEDs are not used in this model.

5.25 Inch Drive Bay

The three 5.25 half-height external drive bays can be configured with a wide variety of drive types. The illustrations in this manual show a 3.5" floppy and a CD-ROM drive installed.

3.5 Inch Drive Bays

The ProRACK 4500 also provides two internal 3.5" drive bays, typically configured with hard drives.

The Rear Panel

The rear panel allows access to these features:

- Power cord connector
- Serial port options
- Parallel port options
- Fan vent
- Expansion slot covers

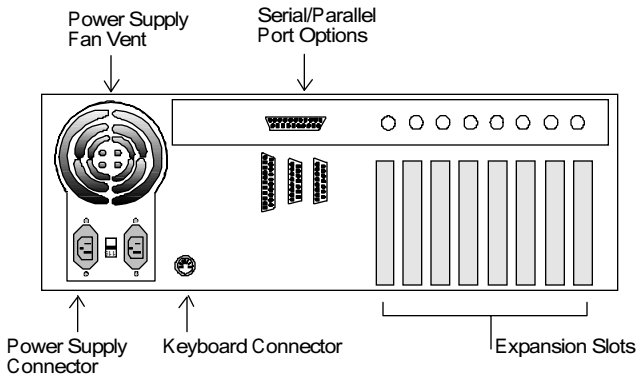

Figure 1-2: The Rear Panel

The ProRACK 4500 can be configured with standard eight- or 12-slot motherboards, or it can be configured with a passive backplane and single board computer.

Serial and parallel port options are available on through the Single Board Computer feature slot (if so configured), or through an associated feature connector slot on the rear of the chassis.

The **Single Board Computer** provides access to several features through the feature connector slot. The features can include a keyboard connector, mouse connector and parallel port connector.

The rear panel also provides twenty **expansion slots** for up to twenty boards.

The standard **power supply** is an auto-sensing model, and does not require a 110/220 volt switch.

The Keyboard (Optional)

The ProRACK 4500 comes with an optional enhanced 101-key keyboard. The keyboard is discussed in greater detail in Section 3 of this publication.

The Power Supply

The 200 watt power supply can facilitate the system, disk drives, and an array of expansion boards. The supply provides its own cooling with a built-in fan.

The system is also available with an optional dual hot swappable 250 watt supplies.

Section 2 - Setting Up the ProRACK

Overview

This section describes the assembly of the chassis. Once everything is connected, the system will be ready to be powered up.

You will connect the monitor cable and the keyboard cable to the system via connectors on the rear panel of the case. You will also connect the power cord to the power connector on the rear panel.

Unpacking the ProRACK

Before proceeding, review this list.

- The main unit
- Power cord
- Keyboard (optional)
- Monitor (optional)
- Mouse (optional)
- Printer cable (printer optional)

Assembling the ProRACK

Remove the protective cardboard insert from the floppy diskette drive(s). Take a moment to study the rear panel (figure 2-1).

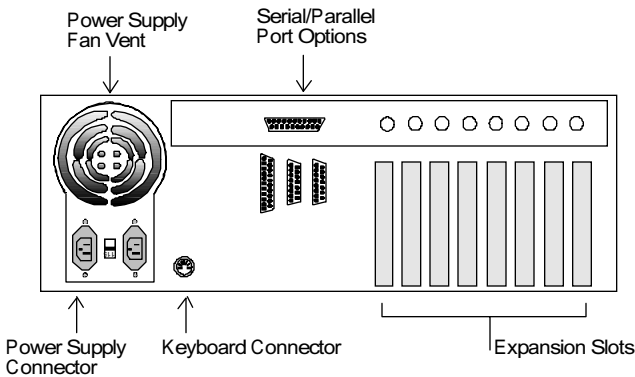

Figure 2-1: The Rear Panel

The Monitor (optional)

Two cables are attached to the rear of the monitor. The grounded, three-pronged cable plugs into a grounded power source. The other cable carries data to the monitor, and plugs into the system's video adapter card.

- 1) Locate the adapter's connector on the rear panel. The adapter is installed in one of the expansion slots.
- 2) Press the plug into the video connector.
- 3) Plug the power cord into a grounded, three-pronged outlet.

The Keyboard (optional)

- 1) Locate the round, five pin keyboard connector on the rear of the case (or rear of the SBC, if so configured).
- 2) Position the keyboard cable plug so that the pins match the connector on the case.
- 3) Firmly press the keyboard's plug into the system keyboard connector.

The Power Cord

The rackmount system comes with an insulated, grounded, three-pronged power cord.

- 1) Locate the grounded, three-pronged power connector on the rear of the case.
- 2) Position the power cord's female connector next to the power connector on the rear of the case and press the plug firmly into place.
- 3) Plug the male end of the power cord into a grounded outlet.

The Mouse (optional)

The rackmount system can be configured with an optional mouse. For software installation, refer to documentation provided with the mouse.

- 1) Locate the nine-pin serial port connector on the rear of the case (refer to figure 2-1).
- 2) Position the mouse plug next to the serial port on the rear of the case and press the plug firmly into place.

The Printer (optional)

- 1) Locate 25-pin parallel port connector on the rear panel.
- 2) Press the printer's data plug firmly into the parallel port connector on the rear panel.

Plug the power connectors for all the devices into a grounded, three-pin power supply. We recommend that you use a power surge protector with the system and peripheral equipment.

Turning the System On

Before Powering Up

If the operating system was not pre-installed, refer to OS User's Guide for details on how to "boot" the first time.

Starting Up

Follow these steps:

- 1) Power up all peripherals first, i.e. printer and monitor.
- 2) Turn the system's ON/OFF toggle to the ON position.
- 3) The system will boot, and load its operating system.

The system's BIOS is configured at the factory with default settings. You can reconfigure the BIOS at any time. Refer to the document titled "Configuration Utilities".

Mounting the ProRACK In Your Rack

Follow these steps to install the slide rails on the ProRACK chassis and mount the ProRACK in your equipment rack:

- 1) Slide the smallest interior portion of the slide completely out of the assembly.
- 2) Mount the smallest interior portion of the slide to the chassis, using the #6/32 screws provided.
- 3) Mount the forward bracket (smallest of the pair) to the front of the largest portion of the slide. Use two of the #10 flat head screws provided.
 - The flat head of the screw will be on the inside of the slide.
 - Put a flat head screw washer next to the bracket assembly, followed by a lock washer and a nut.
 - Adjust the bracket until it is even with, or slightly ahead of the front of the large portion of the slide.
 - Tighten the screws and nuts.
- 4) Mount the rear bracket (longest of pair) to the rear of the largest portion of the slide.
 - This bracket is an extender. You will need to match up holes that will let you mount the bracket to the rear rail.
 - Hand tighten the screws and nuts. Tighten these **after** the ProRACK is installed.
- 5) Reassemble the slides.
- 6) When you mount the ProRACK, the front of the bracket will mount to the rear of your rack's forward rail. The rear extender may be mounted in front of, or behind the rear rail. The brackets are mounted to the RETMA rails using #10 screws.

Section 3 - Using the ProRACK

Overview

Use this section to become familiar with and use your ProRACK's features:

- The Front Panel LEDs and Controls
- The Keyboard
- Floppy Diskettes
- Installing Disk Drives
- Using the Power Supply
- Rebooting the System
- Maintaining the System

The Front Panel

Features

Located on the control panel are the ON/OFF switch, the keylock and the system reset button.

ON/OFF Switch This switch controls the main power to the system. The power supply(s) also have an external ON/OFF switch.

Keylock The keylock feature allows you to lock out the keyboard, prohibiting any input through it.

Reset button The reset button allows you to perform a warm boot.

Front Panel LEDs

Two LEDs display important information about the System:

Power LED The power LED lights while the system is turned on and receiving power.

Disk Drive LED The disk drive LED lights whenever the hard disk drive is accessed.

The Keyboard (Optional)

The keyboard can be used to input information and commands to the computer. Or it can be disabled as an interface device. The keyboard is divided into four sections:

- Function keys
- Cursor control keys
- Alphabetic typing keys
- Numeric keypad

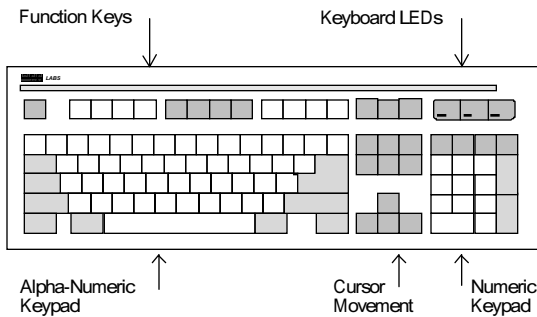

Figure 3-1: The Keyboard (Optional)

Function Keys The function keys perform special commands which are provided by software running on the system.

Keyboard LEDs The LEDs indicate whether the Num Lock, Caps Lock and Scroll Lock functions are enabled.

Alpha Numeric Keypad These keys are used to enter commands into the system.

Cursor Movement The cursor movement keys are used to move the cursor in many text-based, without typing characters or null spaces. They are also used in many utilities and programs which do not provide mouse support.

Numeric Keypad The numeric keypad, when enabled through the Num Lock command, allows you to use the keypad exactly as you would a calculator.

Floppy Diskettes

The chassis facilitates up to three external 3.5" drives or three half-height 5.25" drives. The drive bays can be configured with 3.5" floppy drives.

Encased in hard plastic, 3.5" *diskettes* measure 3.5 inches per side. The diskette is inserted metal-edge first, with the label side facing up.

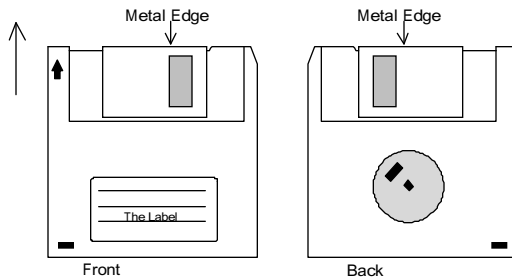

Figure 3-2: 3.5 Inch Floppy Disk

Rebooting the Computer

There are two methods for restarting the system:

Cold or Hard Boot The power supply is turned off and then on. The system starts up, runs the memory test and boots from the system disk. It is more complete than a warm boot.

Warm or Soft Boot Use the keyboard command: <Ctrl> <Alt> A warm boot takes less time than a cold boot. Instead of restarting from power-down, the system simply clears RAM and runs certain commands from the boot files.

Installing Drives

Before proceeding, be sure to unplug the power supply. Installing a drive is simple and easy. Follow these steps:

- 1) Remove the system cover.
- 2) Select a position for the drive to be placed within the system. Full-height drives require two bays. Remember to install drives from top to bottom.

If you are installing a 3.5” internal drive, select and remove a drive holder assembly from the chassis.

- 3) Slide the drive into position.
- 4) Thread the retaining screws through the screw openings in the chassis, or drive holder assembly, and into their receptacles on the drive. Use the original screws included with the drive. Longer screws may damage the drive.

If you are installing a 3.5” internal drive, reinstall the drive holder assembly from into the chassis.

- 5) Connect one of the disk drive power plugs to the drive. The plug and socket are notched. Make sure they match correctly.
- 6) Connect the data cable required for the drive, and controller. Refer to documentation provided by the drive and controller manufacturers.
- 7) Reconfigure the system utilities and format the new drive, as needed.
- 8) Re-install and attach the system cover.

Using the Power Supply

The ProRACK 4500 is configured with a 200 watt power supply, with five disk drive power cords, automatic short circuit shutdown. It can be configured to operate with 110 VAC or 220 VAC.

110 VAC at 60 Hz is the standard line voltage and frequency used in the United States. 220 VAC at 60 Hz is the standard voltage and frequency used in Europe and other nations.

Setting 110 or 220 VAC

The power supply may be set to operate at either 110 VAC or 220 VAC. Find the red selector switch on the back of the case. The switch is clearly marked and displays its setting.

Standard Maintenance

Follow these guidelines in maintaining the system

- Do not eat, drink or smoke near the computer.
- Use a surge protector with your system and any peripheral devices. Surges of power can destroy computer components and can also destroy data on an entire hard drive.
- Do not allow any magnetic sources to come near the machine, such as magnets or electric motors. These will damage data on your disks.
- Do not let the computer share an electrical circuit with a noisy electric motor, such as a blender or a vacuum cleaner.
- Ground yourself before touching any exposed circuitry by touching the system case. This discharges static electricity in your body, which can damage delicate components.