

**Technical Reference**  
**PB-11109**  
20-Slot Passive Backplane



1641 McGaw Avenue  
Irvine, California 92614



## Features

- 1 Single Board Computer (SBC) connector for easy upgrades through the latest Pentium<sup>®</sup>, Pentium<sup>®</sup> Pro and Pentium<sup>®</sup> II products. The SBC is compatible with any CSS Single Board Computer
- 11 ISA slots and 9 PCI slots
- Basic connectors provided for speakers, hard disk LED, reset/turbo LED, keylock, PS/2 mouse and CMOS battery
- Power connectors for both 5 volt and 3 volt power source
- Auxiliary 5 volt power connectors for flexibility in backplane-to-chassis mounting
- Power supply lugs for higher currency power supplies

## FCC Standards

The FCC (Federal Communications Commission) restricts the amount of radiation and radio frequency emissions coming from computing equipment.

**Note:** This equipment has been tested and found to comply with the limits for a Class B digital device pursuant to Part 15 of the FCC Rules. These limits are designed to provide reasonable protection against harmful interference in a residential installation. This equipment generates, uses, and can radiate radio frequency energy and, if not installed and used in accordance with the instructions, may cause harmful interference to radio communications. However, there is no guarantee that interference will not occur in a particular installation. If this equipment does cause harmful interference to radio or television reception, which can be determined by turning the equipment off and on, the user is encouraged to try to correct the interference by one or more of the following measures:

- Reorient or relocate the receiving antenna.
- Increase the separation between the equipment and receiver.
- Connect the equipment into an outlet on a circuit different from that to which the receiver is connected.
- Consult the dealer or an experienced radio/TV technician for help.

CSS Labs is not responsible for any radio or television interference caused by unauthorized modifications to this equipment. Operation with non-certified peripherals is likely to result in interference to radio and TV reception.

To ensure compliance to FCC noninterference regulations, peripherals attached to this device require shielded I/O cables.

**NOTICE:** The use of a non-shielded I/O cable with this device is in violation of U.S. Federal law and will not allow the device to meet the maximum emission limits.

**CAUTION:** Any changes or modifications not expressly approved by the grantee of this device could void the user's authority to operate the equipment.

**Note:** If you have purchased the miniature tower system, please note the following...

**WARNING:** The system is to be installed on desk or table tops only. The unit will become unstable if operated as a floor standing unit and unintentional force is applied to the top of the unit.

Turn the unit off and unplug the power cord before you open the cover to install any cards or peripheral devices.

## WARNING

CAUTION: THERE IS A DANGER OF EXPLOSION IF THE BATTERY IS INCORRECTLY REPLACED. REPLACE ONLY WITH THE SAME OR EQUIVALENT TYPE RECOMMENDED BY THE MANUFACTURER. DISCARD USED BATTERIES ACCORDING TO THE MANUFACTURER'S INSTRUCTIONS.

ATTENTION: IL Y A DANGER D'EXPLOSION S'IL Y A REMPLACEMENT INCORRECT DE LA BATTERIE. REMPLACER UNIQUEMENT AVEC UNE BATTERIE DU MEME TYPE OU D'UN TYPE RECOMMENDE PAR LE CONSTRUCTEUR. ETTERAU REBUT LES BATTERIES USAGEES CONFORMEMANT AUX INSTRUCTIONS DU FABRICATANT.

# NOTICE

The information within this manual is subject to change without notice.

CSS Laboratories, Incorporated shall not be held liable for technical or editorial errors or omissions contained in herein; nor for incidental or consequential damages resulting from the furnishing, performance or use of this material.

No part of this publication may be reproduced, stored in a retrieval system, or transmitted, in any form or by any means, mechanical, photocopying, recording or otherwise, without the prior written permission of CSS Laboratories, Inc.

Product names mentioned herein are for identification purposes only, and may be trademarks and/or registered trademarks of their respective companies.

© 1998 CSS Laboratories, Inc. All rights reserved.  
P/N PB-11109-DOC Revision 1, January, 1998

---

# Table of Contents

Overview .....	1
Basic Features .....	1
Connectors .....	1
Single Board Computer Bus .....	1
PCI Bus Bridge .....	1
High Currency Power Supplies .....	2
The Board .....	3
Connectors .....	4
5 Volt Power Connector P1; Auxiliary Connector .....	4
3 Volt Power Supply Connector P2 .....	5
Speaker Connector J168 .....	5
Hard Drive LED J169 .....	5
Add-In Controller Hard Drive LED HDLED .....	6
Reset/Turbo Connector RST .....	6
Front Panel Connector FP .....	6
Infrared Connector IR .....	7
Power LED/Keylock KEYLOC .....	7
Battery Connector BAT .....	7





# Overview

This section describes the connectors and their functions.

## Basic Features

### Connectors

A hard disk activity indicator LED connectors is provided for either an add-in or single board computer (SBC) on-board controller. Front panel, reset/turbo, mouse, speaker and keylock connector are also provided.

5 volt and 3.3 volt power connectors on the board supply power to the ISA and PCI busses, add-in boards and SBC. Auxiliary sets are provided in alternate locations.

Also provided is a connector for infrared-based peripheral devices. The connector attaches to an add-in transceiver.

### Single Board Computer Bus

To facilitate CSS SBCs, the backplane uses a basic ISA bus architecture with a PCI bus extension. CSS backplanes accept all CSS single board computers.

### PCI Bus Bridge

The PCI bus architecture design imposes a four PCI bus per system limit. CSS's passive backplane expand beyond this limitation by incorporating a PCI bridge onto the board.

On the PB-11109 passive backplane with nine PCI busses, the first two PCI busses communicate directly with the associated SBC. The two PCI busses operate at PCI level 0.

The last seven PCI busses communicate with the SBC through the PCI bridge. These PCI busses operate at PCI level 1. The following diagram illustrates the bus arrangement:

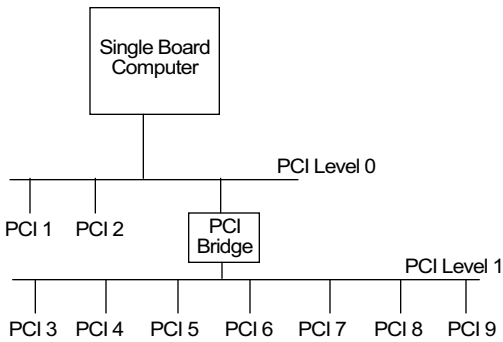

Figure 1: A Nine PCI Bus Passive Backplane

## High Currency Power Supplies

A set of two terminal lugs are provided for systems requiring high currency power supplies.

# The Board

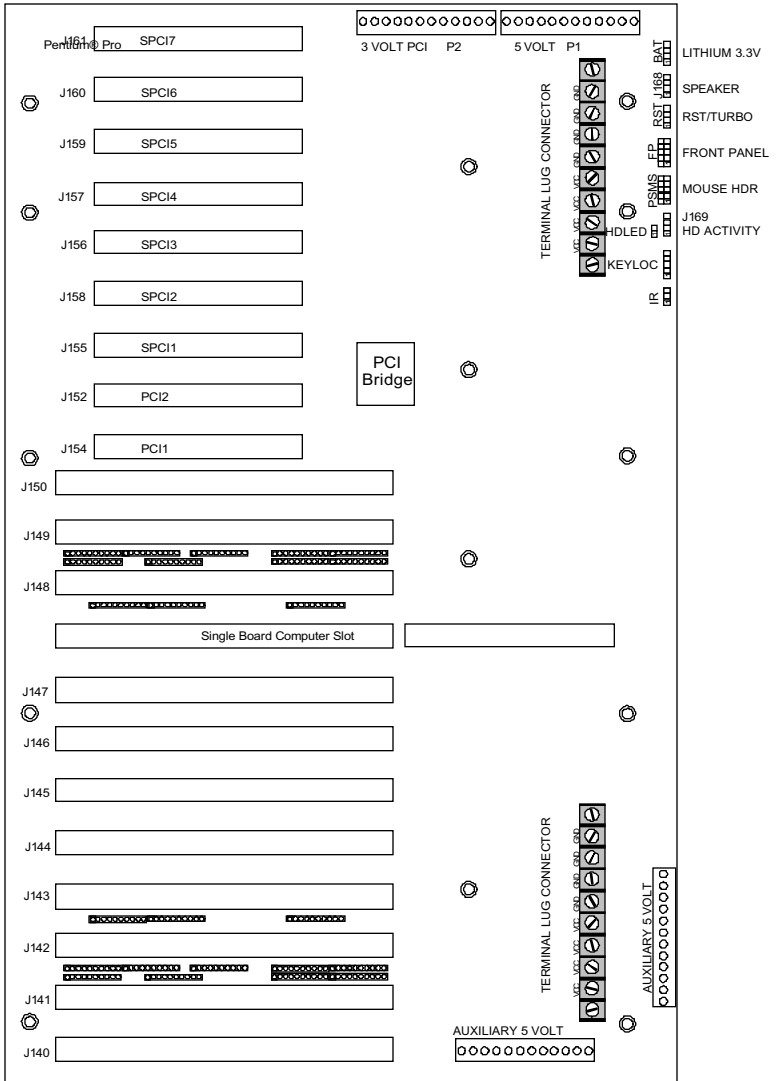

Figure 2: The Passive Backplane

# Connectors

The PB-11109 20-slot passive backplane provide the following connectors:

- P1 - 5 volt power
- P2 - 3 volt power
- Auxiliary 5 volt (2)
- J168 - Speaker
- J169 - Hard drive activity LED
- HDLED - Add-in controller hard drive activity LED
- RST - Reset/Turbo LED
- FP - Front Panel
- IR - Infrared
- KEYLOC - Power LED and Keylock
- BAT - 3.3 volt battery

## 5 Volt Power Connector P1; Auxiliary Connector

The connectors attach the board to the power via the 5 volt regulator. Orient the plugs' black wires to sit side-by-side.

Pin	Assignment	Pin	Assignment
1	Power good	7	Ground
2	+5Vdc	8	Ground
3	+12 Vdc	9	-5 Vdc
4	-12 Vdc	10	+5 Vdc
5	Ground	11	+5 Vdc
6	Ground	12	+5 Vdc

### 3 Volt Power Supply Connector P2

The connectors attach the board to the power via the 3 volt regulator. Orient the plugs' black wires to sit side-by-side.

Pin	Assignment	Pin	Assignment
1	Ground	7	+3.3 Vdc
2	Ground	8	+3.3 Vdc
3	Ground	9	+3.3 Vdc
4	3.3 Vdc	10	Ground
5	3.3 Vdc	11	Ground
6	+3.3 Vdc	12	Ground

### Speaker Connector J168

The speaker connector attaches to a standard chassis speaker.

Pin	Assignment
1	Speaker (-)
2	Not Used
3	Ground
4	Speaker (+)

### Hard Drive LED J169

This connector attaches the hard drive access LED to the front panel for the on-board SBC controller. The LED lights when the drive is accessed.

Pin	Assignment	Pin	Assignment
1	HD LED	3	HD LED
2	Power	4	Power

## Add-In Controller Hard Drive LED HDLED

This connector attaches a hard drive access LED to the front panel for an add-in controller. The LED lights when the drive is accessed.

Pin	Assignment
1	HD LED
2	Power

## Reset/Turbo Connector RST

The reset button lets you perform a “warm boot” without turning the system off. The turbo LED indicates the system is running at the higher clock speed when it lights.

Pin	Assignment	Pin	Assignment
1	Reset	3	Turbo LED
2	Ground	4	Ground

## Front Panel Connector FP

This 10-pin connector is the interface between the system board and the control panel on the front of the system case.

Pin	Assignment	Pin	Assignment
1	Ground	6	Ground
2	Power LED	7	LED on
3	HD LED	8	Keylock
4	Not used	9	Power LED
5	Power LED	10	Reset

## **Infrared Connector IR**

This two-pin connector attaches to an optional infrared add-in controller. Infrared controllers can act as ports for a number of peripheral devices including mouse, printer and keyboard.

## **Power LED/Keylock KEYLOC**

The power LED lights while the system is powered up. The keylock disables the keyboard.

<b>Pin</b>	<b>Assignment</b>
1	Power LED
2	Not used
3	Ground
4	Keylock
5	Ground

## **Battery Connector BAT**

The connector attaches the 3.3 volt lithium battery to the board. The battery provides constant power to the single board computer's CMOS and has a typical life-span of five years.

<b>Pin</b>	<b>Assignment</b>
1	Battery Power
2	Not Used
3	Not used
4	Ground

